

ZN63A-12(VS1) Indoor High-Voltage AC Vacuum Circuit Breaker



1 Product overview

- 1.1 Suitable for switching various loads with different properties and frequent operations in three-phase AC 50Hz, 10kV power system.
- 1.2 For protection and control of electrical equipment used in industrial and mining, enterprises, power plant, and substation.
- 1.3 With central handcart type switch cabinet and XGN fixed type switch cabinet provided for KYN28A-12(GZS1).
- 1.4 Available standards
 - GB/T 1984-2014 High-voltage alternating-current circuit-breakers
 - GB/T 11022-2011 Common specifications for high-voltage switchgear and controlgear standards
 - DL/T 402-2016 High-voltage alternating-current circuit-breakers

2 Type designation

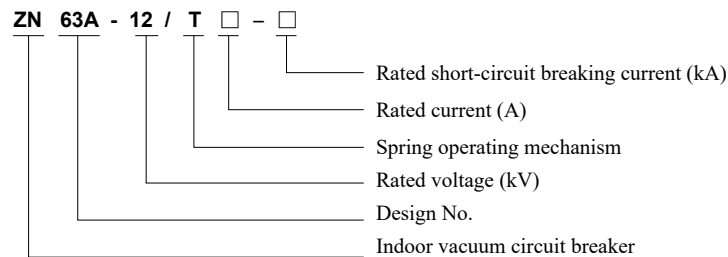

3 Product parameters



No.	Name	Unit	Value		
1	Rated voltage	kV	12		
2	Rated power frequency withstand voltage (1 minute)		42		
3	Rated lightning impulse withstand voltage (peak)		75		
4	Rated frequency	Hz	50		
5	Rated current	A	630 1250	630 1250 1600 2000 2500 3150	1250 1600 2000 2500 3150 4000
6	Rated circuit-breaker breaking current	kA	20、25	31.5	40
7	Rated short-circuit making current (peak)		50、63	80	100
8	Rated short-time withstand current		20、25	31.5	40
9	Rated peak withstand current		50、63	80	100
10	Rated short-circuit duration	S	4		
11	Rated operating sequence		O—0.3s—CO—180s—CO		O—180s—CO—180s—CO
12	Rated short-circuit breaking current ON/OFF times	Times	30 (50 customized)		
13	Mechanical life		10000 (20000 customized)		
14	Rated operating voltage	V	AC/DC220、 AC/DC110		
15	Allowable accumulative wear thickness of dynamic and static contacts	mm	3		

Note: A forced air-cooled is required for 4000A and above rated current.

ZN63A-12(VS1) Indoor High-Voltage AC Vacuum Circuit Breaker

4 Working environment conditions

- 4.1 The ambient air temperature does not exceed 40°C, the average measured within 24h does not exceed 35°C, and the minimum ambient air temperature is -15°C;
- 4.2 Altitude: Not higher than 1000m;
- 4.3 The surrounding air is not polluted obviously by dust, smoke, corrosive or flammable gas, steam, and salt mist;
- 4.4 Humidity conditions: daily mean value is not greater than 95%; monthly mean value is not greater than 90%; the average of water vapor pressure is not greater than 2.2kPa; the average of the monthly water steam pressure is not greater than 1.8KPa;
- 4.5 Vibration or ground movement from the outside of switchgear or control equipment can be negligible;
- 4.6 The amplitude of the conducted electromagnetic interference in the secondary system cannot exceed 1.6kV;
- 4.7 Special use conditions
If the altitude at the installation site exceeds 1000m, or the ambient air temperature exceeds the limit specified in the normal working conditions or the installation site is highly humid to easily cause condensation, please contact our company for customization.

5 Technical features of product

- 5.1 Excellent performance of circuit breaker
 - 5.1.1 The arc extinguish chamber and operating mechanism of circuit breaker are configured at front and rear, and are connected into a whole through the transmission mechanism.
 - 5.1.2 The mechanical life is not below 10000 times.
 - 5.2 The advanced vacuum arc extinguish chamber uses copper-chromium alloy contact and longitudinal magnetic field contact structure.
- 5.3 Enhanced insulating cylinder
 - 5.3.1 The insulating cylinder is formed with new APG process.
 - 5.3.2 The inner skirt edge and reinforced ribs are provided in the insulating cylinder, improving the insulation level and dynamic stable current resistant capacity.
 - 5.3.3 The vacuum arc extinguish chamber is installed in an insulating cylinder to efficiently prevent damage and surface contamination due to foreign matters while shortening the overall size of circuit breaker obviously.
- 5.4 Flexible and simple operating mechanism
 - 5.4.1 The operating mechanism is of the spring energy-storage type with electric and manual energy storage functions.
 - 5.4.2 When the circuit breaker is working, the energy from the energy-storage spring will be transferred to the link mechanism through the output cam and then to the dynamic contact through the link mechanism.
 - 5.4.3 With advanced and reasonable damping device, the break-brake rebound is small.
 - 5.4.4 No adjustment is required with very little maintenance.

ZN63A-12(VS1) Indoor High-Voltage AC Vacuum Circuit Breaker

6 Outline and installation dimensions

6.1 Outline and installation dimensions of ZN63A-12(VS1) handcart type circuit breaker

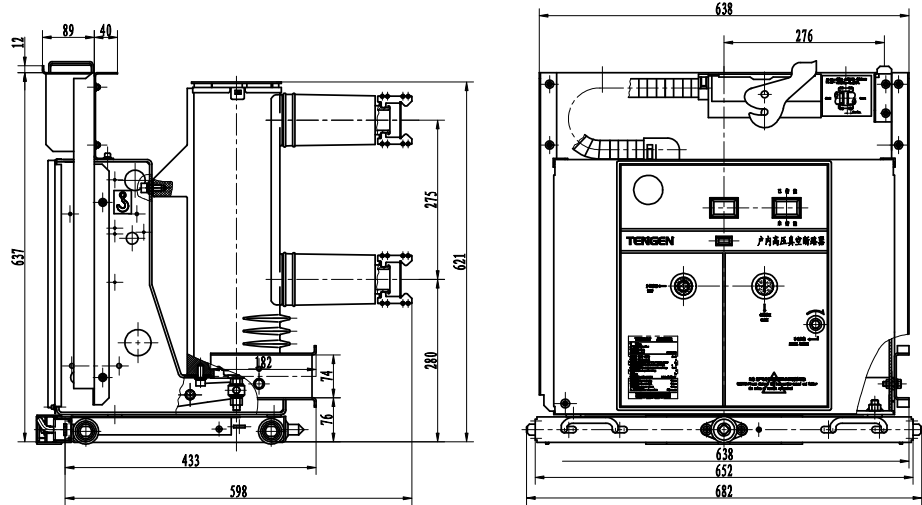

Note: The stroke of handcart is 200 ± 2 mm, and the meshing size of dynamic and static contacts is ≥ 15 mm.

Rated current (A)	630	1250	1600
Rated short-circuit breaking current (kA)	20, 25	25, 31.5, 40	31.5
Size of matched static contact (mm)	$\Phi 35$	$\Phi 49$	$\Phi 55$

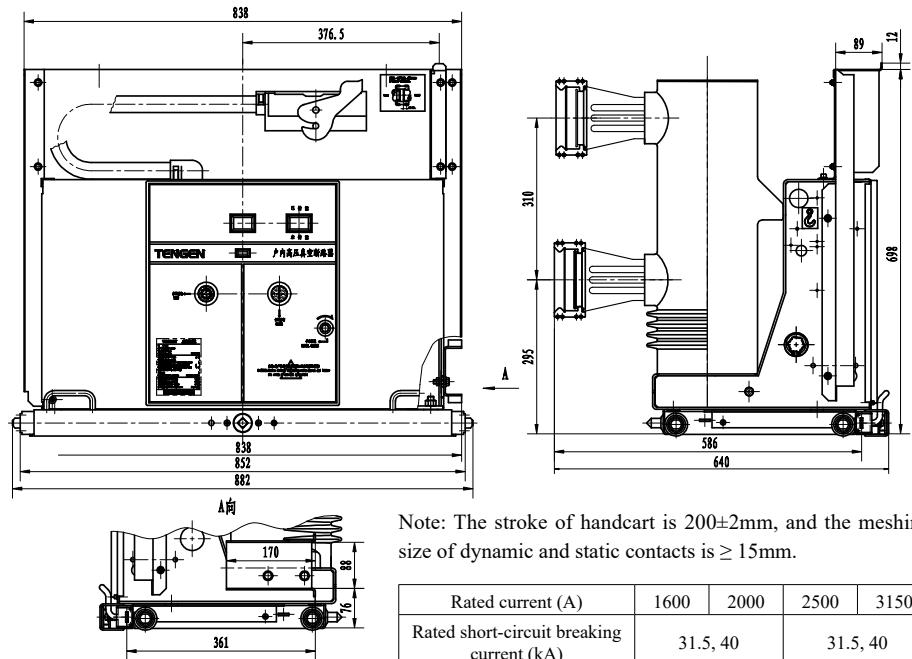

Note: The stroke of handcart is 200 ± 2 mm, and the meshing size of dynamic and static contacts is ≥ 15 mm.

Rated current (A)	1600	2000	2500	3150
Rated short-circuit breaking current (kA)	31.5, 40		31.5, 40	
Size of matched static contact (mm)	$\Phi 79$		$\Phi 109$	

ZN63A-12(VS1) Indoor High-Voltage AC Vacuum Circuit Breaker

6.2 Outline and installation dimensions of ZN63A-12(VS1) fixed circuit breaker

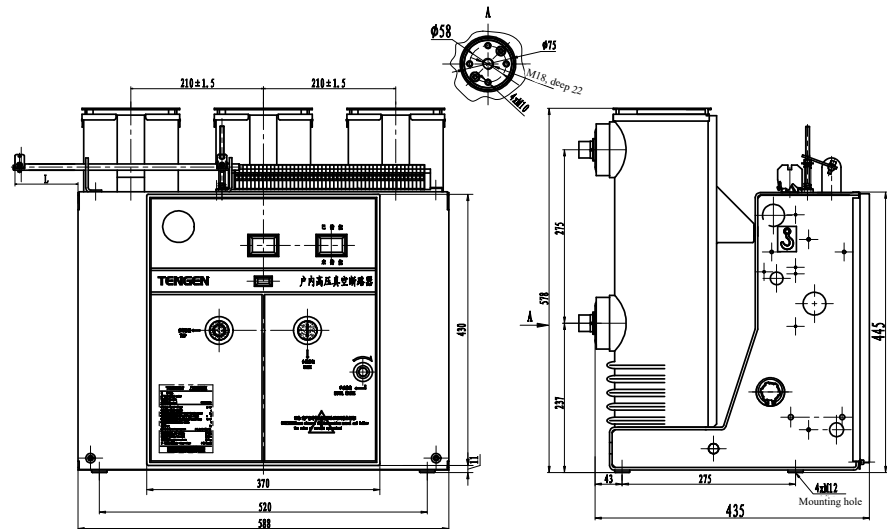

Rated current (A)	630	1250	1600
Rated short-circuit breaking current (kA)	20, 25, 31.5	25, 31.5, 40	31.5, 40
Top interlock of mechanism, L (mm)	50, 100, 150, 200 (there are left and right extended interlocks, and the length can be customized according to the customer requirements)		

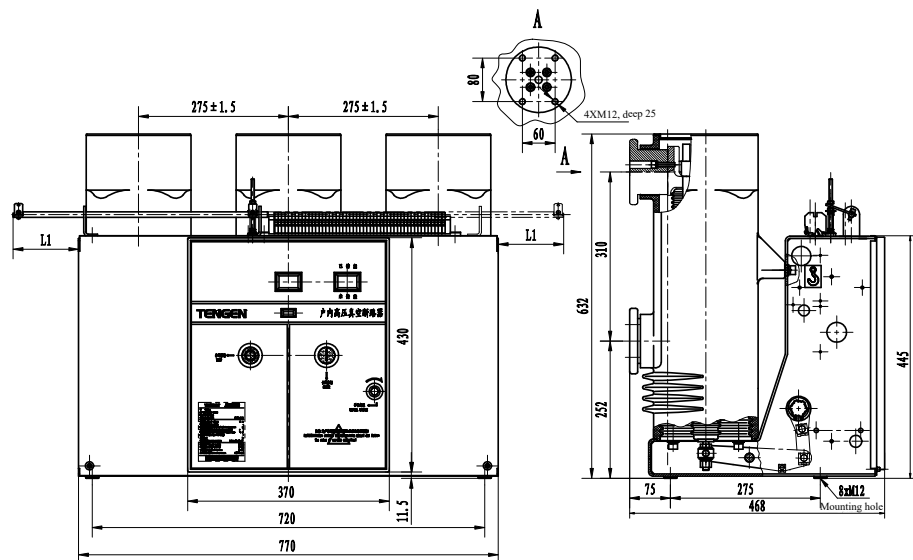

Rated current (A)	1600	2000	2500	3150
Rated short-circuit breaking current (kA)	31.5, 40			
Top interlock of mechanism, L (mm)	50, 100, 150, 200 (there are left and right extended interlocks, and the length can be customized according to the customer requirements)			

ZN63A-12(VS1) Indoor High-Voltage AC Vacuum Circuit Breaker

6.3 Outline and installation dimensions of ZN63A-12(VS1) side-mounted fixed type circuit breaker

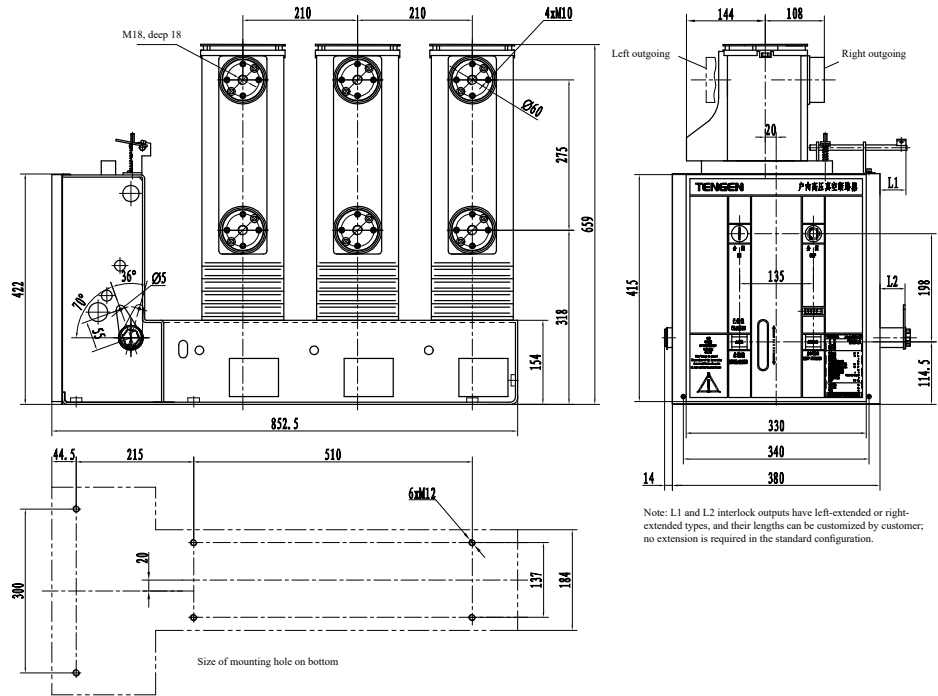

7 Secondary scheme schematic diagram

7.1 Handcart type scheme

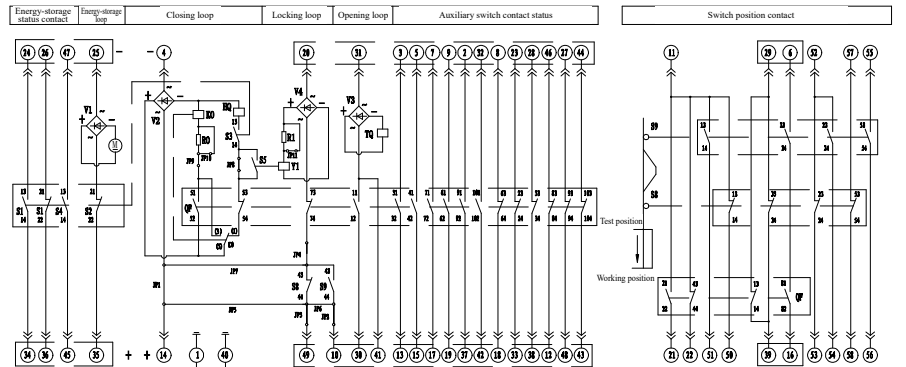

Option wiring configuration:		ab	bg	cf	cd	af	ag	bc	ij	lk
Configuration	JP1	JP2	JP3	JP4	JP5	JP6	JP7	JP8	JP9	
With wire	With lock	✓	✓	✓	✓	✓	✓	✓	✓	✓
Without wire	Without lock	✓	✓	✓	✓	✓	✓	✓	✓	✓
With wire	With lock	✓	✓	✓	✓	✓	✓	✓	✓	✓
Without wire	Without lock	✓	✓	✓	✓	✓	✓	✓	✓	✓

Selection of operating power supply:		1m	QP	T (1-58)	58-core aviation plug
Operating power supply	JP10	JP11	JP12	JP13	JP14
AC/DC220V	✓	✓	✓	✓	✓
AC/DC110V	✓	✓	✓	✓	✓

TQ	Opening trip coil
S9	Auxiliary switch (switched at work position)
S8	Auxiliary switch (switched at test position)
JP1-JP11	Jumper cable
S5	Locked electromagnet micro switch (optional)
S1-S4	Limit switch (switched after energy storage of the closing spring)
QF	Auxiliary switch 10-ONs and 10-OFFs (switched at the ON/OFF state)

Note: "✓" means disconnection, and "✓" means connection

Notes:

1. The circuit breaker is at the test position, is opened and at the non-energy-storage state.
2. The polarities marked in the dashed box shall be the same during the DC power operation, and the motor shall be wired according to the polarity shown in figure.

ZN63A-12(VS1) Indoor High-Voltage AC Vacuum Circuit Breaker

7.2 Fixed type scheme

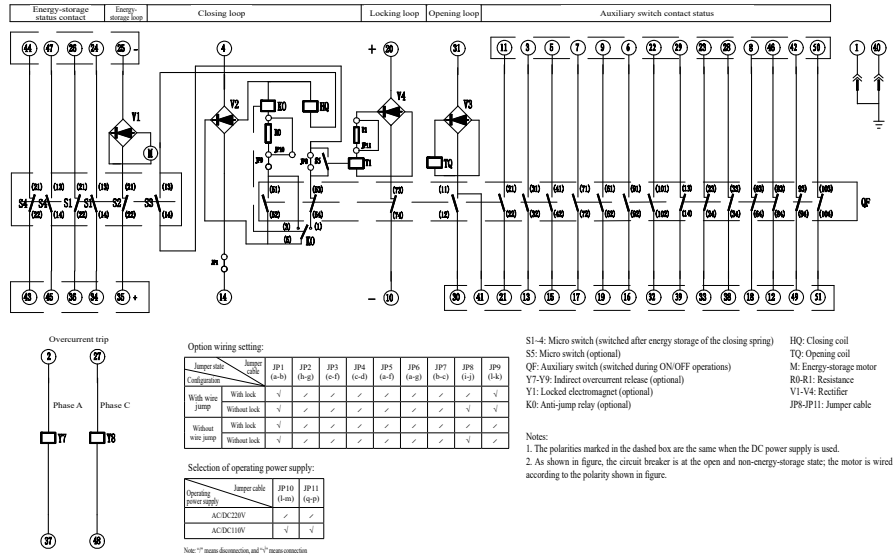

7.3 Side-mounted fixed type scheme

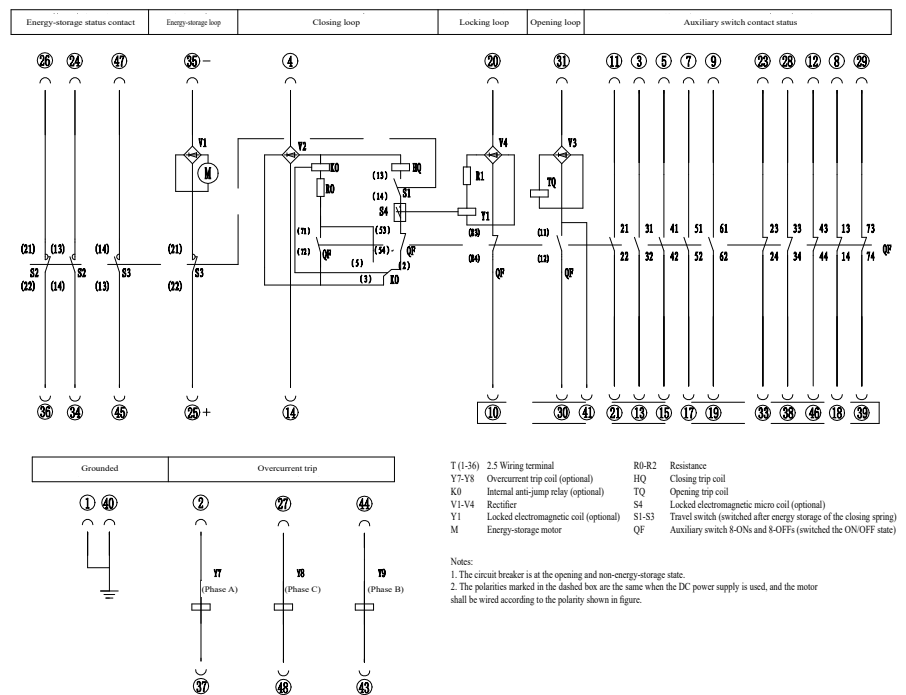

ZN63A-12(VS1) Indoor High-Voltage AC Vacuum Circuit Breaker

8 Order technology confirmation form

ZN63A-12(VS1) Order technology confirmation form

Determine your requirements according to the items listed in table below:

Product model	<input type="checkbox"/> Handcart type <input type="checkbox"/> Fixed type <input type="checkbox"/> Side-mounted fixed type (<input type="checkbox"/> Left outgoing <input type="checkbox"/> Right outgoing)	
Order quantity (pcs)		Primary structure: Insulated cylinder type
Rated current (A)	<input type="checkbox"/> 630 <input type="checkbox"/> 1250 <input type="checkbox"/> Others ___	
Rated short-circuit breaking current (kA)	<input type="checkbox"/> 20 <input type="checkbox"/> 25 <input type="checkbox"/> 31.5 <input type="checkbox"/> 40	
Phase distancing (mm)	<input type="checkbox"/> 210 <input type="checkbox"/> 275	
Operating voltage (V)	<input type="checkbox"/> AC/DC220 (Standard configuration) <input type="checkbox"/> Others___	
Prevent reclosure device	<input type="checkbox"/> Without Prevent reclosure device (standard configuration) <input type="checkbox"/> With Prevent reclosure device	
Locking device	Closing lock: <input type="checkbox"/> No lock (standard configuration) <input type="checkbox"/> With lock, operating voltage___V Handcart lock: <input type="checkbox"/> No lock (standard configuration) <input type="checkbox"/> With lock, operating voltage___V	
Overcurrent device	<input type="checkbox"/> No overcurrent (standard configuration) <input type="checkbox"/> Overcurrent of Phases A and C <input type="checkbox"/> Overcurrent of Phases A, B, and Note: The action current of the standard overcurrent coil is 5A	
Handcart chassis cart option (This item is not available for fixed type)	Grounded: <input type="checkbox"/> Bottom friction grounded (standard configuration) <input type="checkbox"/> Rails grounded at both sides <input type="checkbox"/> Contact grounded Program lock: <input type="checkbox"/> No (standard configuration) <input type="checkbox"/> Locking mechanism <input type="checkbox"/> With chassis cart locked <input type="checkbox"/> With circuit breaker baffle locked Cabinet door interlock: <input type="checkbox"/> No (standard configuration) <input type="checkbox"/> With door closing interlock function	
Fixed circuit interlock output (mm) (This item is not available for handcart type)	Top opening interlock extended: <input type="checkbox"/> Left (standard configuration 100)___ <input type="checkbox"/> Right ___ <input type="checkbox"/> No	
	Spindle extended: <input type="checkbox"/> No (standard configuration) <input type="checkbox"/> Left___ <input type="checkbox"/> Right___	
Secondary wiring scheme	<input type="checkbox"/> TENGEN's standard scheme (see catalog) <input type="checkbox"/> No-standard scheme (scheme should be provided)	
Outline dimensions	<input type="checkbox"/> TENGEN's standard scheme (see catalog) <input type="checkbox"/> No-standard scheme (scheme should be provided)	
Other special requirements		Ordering unit (seal) Sign: Confirmation date: Tel:

Note: If not ticked, all options shall be manufactured according to the TENGEN's standard configurations.